



**Falcon**<sup>TM</sup>

**CNC TOOL HOLDING SYSTEMS**



[www.falcontoolings.com](http://www.falcontoolings.com)

**P**RECISION... **R**ELIABILITY... **E**CONOMY...



**Falcon™**

World class products

Precise quality

Assured economy

Good reliability

---

SATISFIED CUSTOMER

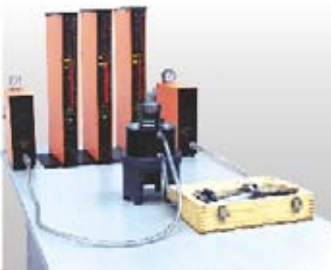

Strategically situated in the city of Coimbatore, which has a large pool of talented human resources and with very good infrastructure.



A combination of CNC machines and good grinding machines ensure that we provide tools of high quality.



A dedicated professional team working in close interaction with customers has enabled us to build "Reliability in People and Products".

# CNC TOOLING SYSTEMS

## AT3 Class Taper

- High precision and rigid tool holding

## Concentricity less than $5\mu$ T.I.R.

- Optimum tool performance

## Balanced Tools

- 6.3g by design
- Up to 2.5G on request

We manufacture customized tools to suit applications based on the component and machine.

Products can be supplied as per DIN 69893 (HSK), MAS403, DIN 69871, DIN 2080, CAT or any other shank types.

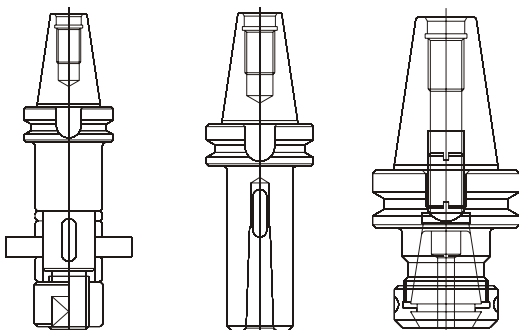
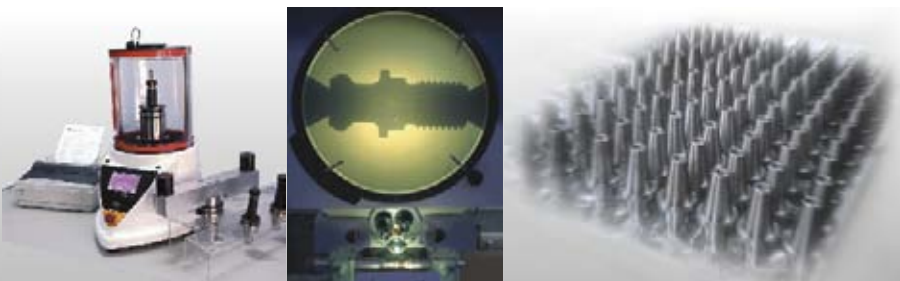

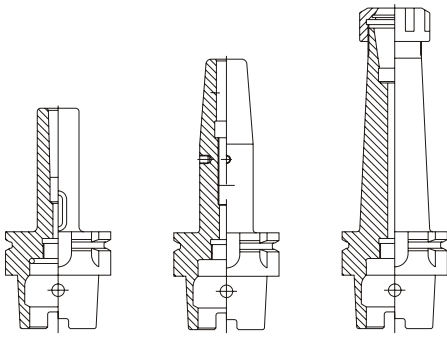

## PRODUCT RANGE

- collet chuck adaptors
- shrink fit holders
- tapping collet chucks
- side lock / endmill holders
- morse taper adaptors
- face mill adaptors
- side and face cutter adaptors
- drill chuck adaptors
- modular boring bars
- customized adaptors and boring bars
- pull studs
- cylindrical sleeves



A Solution to every APPLICATION

# **BALANCED** TOOL HOLDERS

## ADVANTAGES OF BALANCING

- Low Vibrations
- Good Surface Finish
- Longer Tool Life
- Lower Maintenance

---

REDUCES COST



DYNAMICALLY **BALANCED**

**2.5G at 15,000 RPM**





SF. No. 205/1 & 2, 207/1, Kuttai Thottam,  
Kalapatti, Coimbatore 641 035, INDIA.

Tel : +91 422 657 9614

E-mail : [sales@falcontoolings.com](mailto:sales@falcontoolings.com)

Web : [www.falcontoolings.com](http://www.falcontoolings.com)